

Specifications

Current rating: 5A AC,DC

Voltage rating: 250V AC,DC

Temperature range: -25°C to +85°C
(including temperature rise)

Contact resistance: Initial value/ 10m Ω Max.

After environmental testing/20m Ω Max.

Insulation resistance: 500M Ω Min.

Withstanding voltage: 1000 V AC/minute

Applicable wire: AWG#18-#22

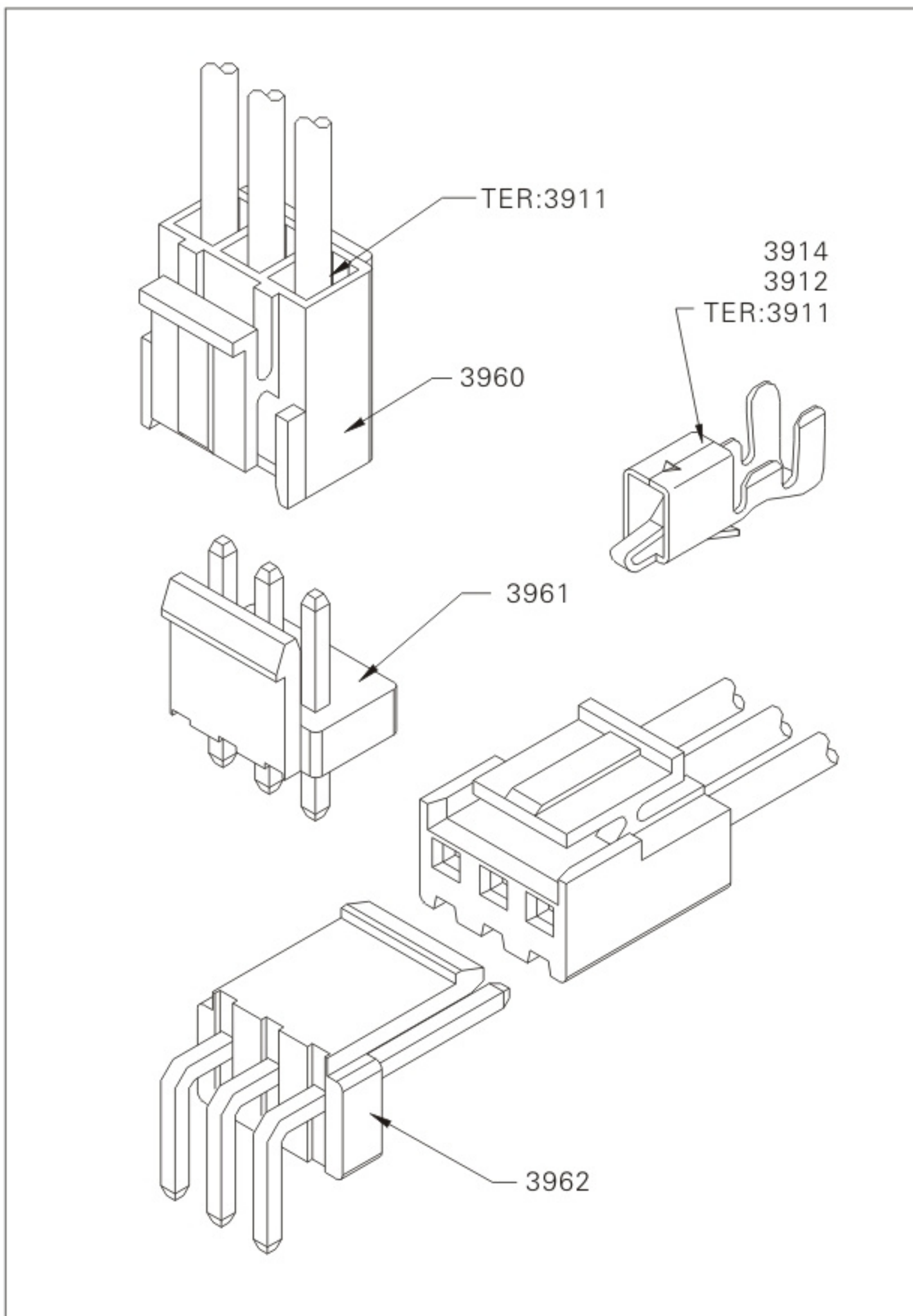

Assembly layout

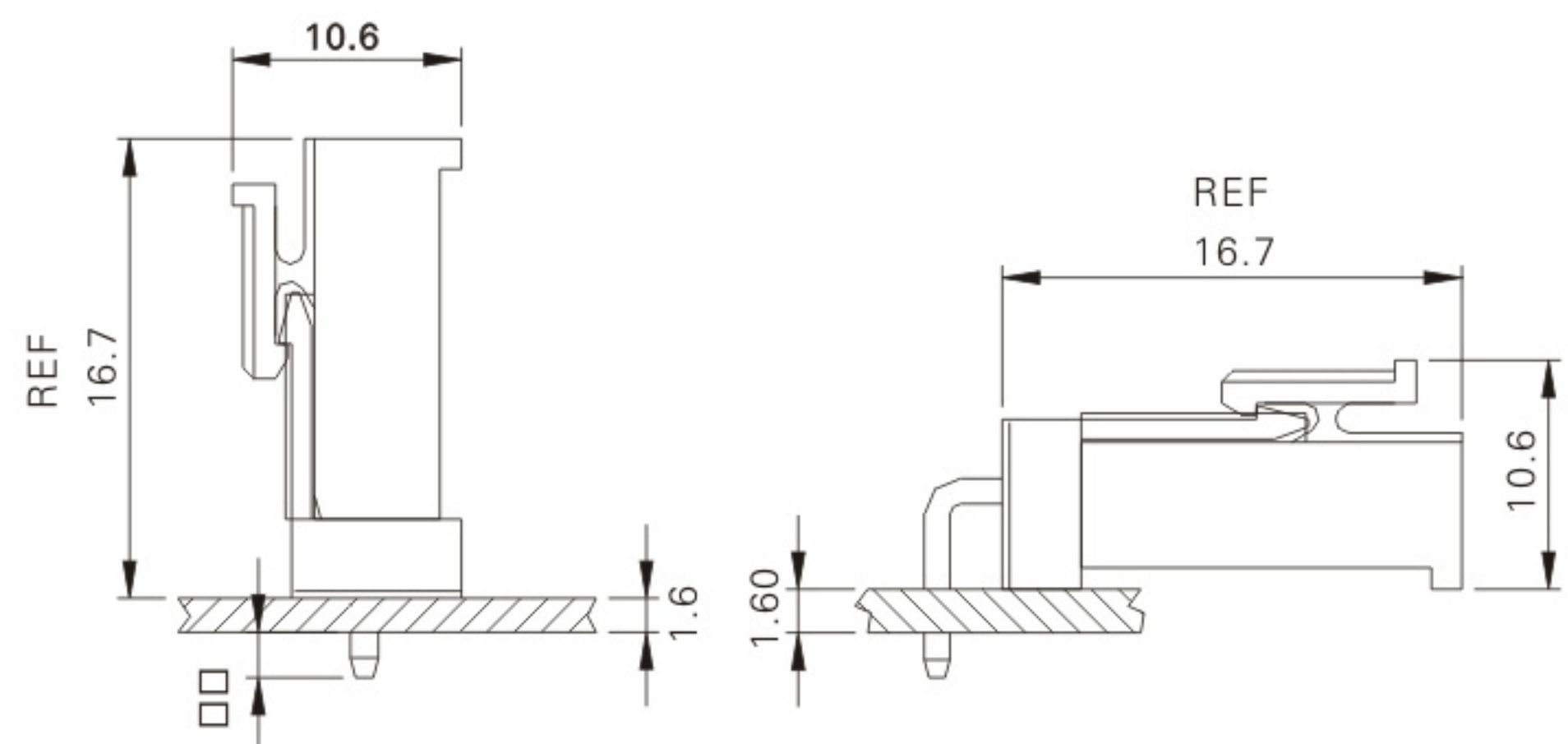

3911/3914 (3.96mm pitch crimp terminal)

Reference Informations:

- *Thickness: 0.25mm
- *Mat'l: Brass or Phosphor Bronze Tin Plated
- *Mates With: 3960 series Housing
- *Accepts With: 3961 3962 series Wafer

P/N	A	B	C	D
3911	4.00	3.90	2.40	2.30
3914	5.00	4.90	3.00	2.90

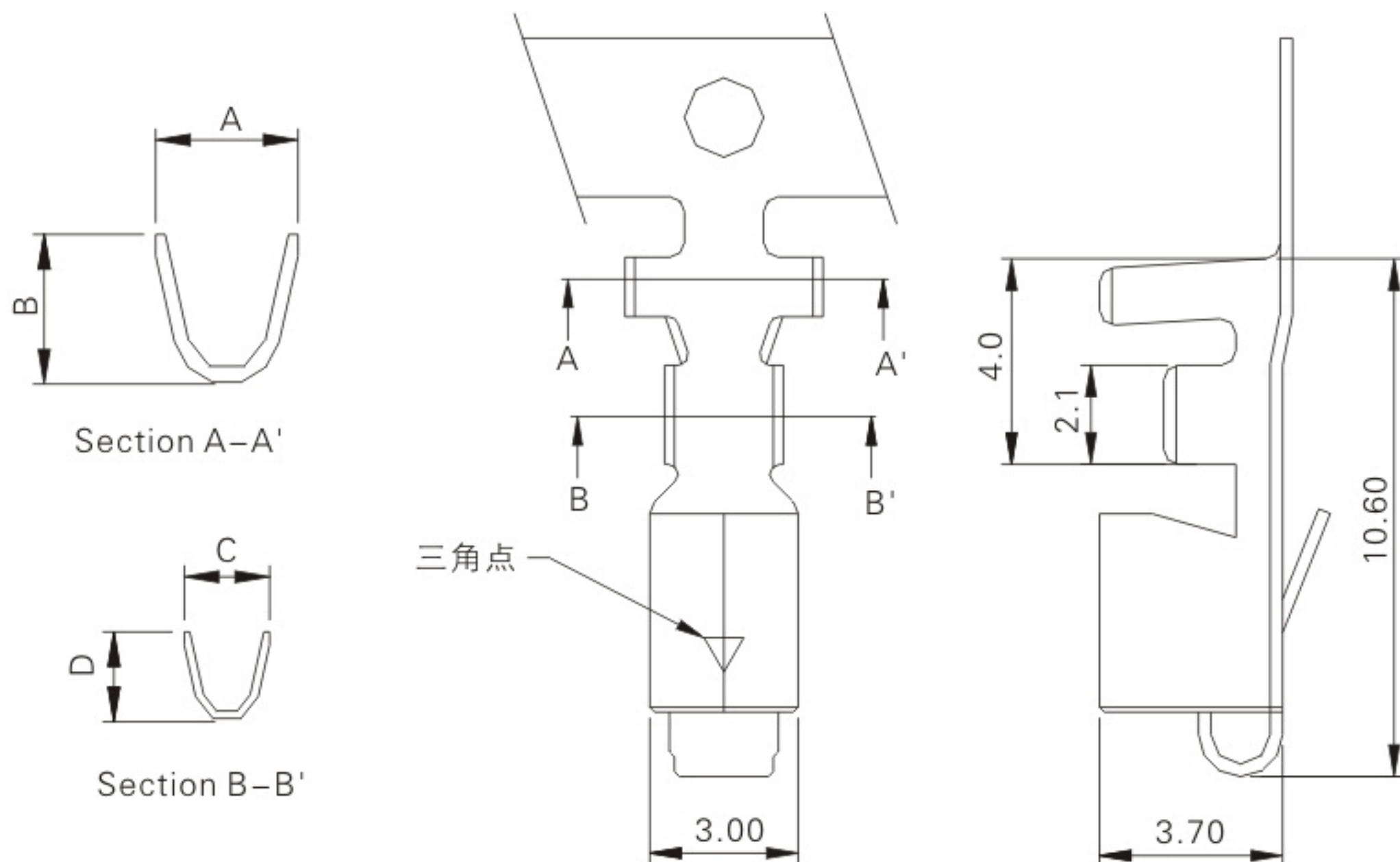

Ordering Information & Specifications

Unit: mm

Part No.	Wire Range	Insulation O.D.	Material	Finish	Qty/reel
3911	AWG#18-22	Φ3.7~Φ1.5	Brass/Phosphor Bronze	Tin-plated	4000
3914	AWG#16-18	Φ4.0~Φ3.7	Brass/Phosphor Bronze	Tin-plated	3500

3960H (3.96mm pitch crimp housing)

Reference Informations:

- *Mat'l: Nylon 66 UL94V-0
- *Mates With: 3911 3914 series Terminal
- *Accepts With: 3961 3962 series Wafer
- *Accepts With 1.14mm(0.45") Square Pins

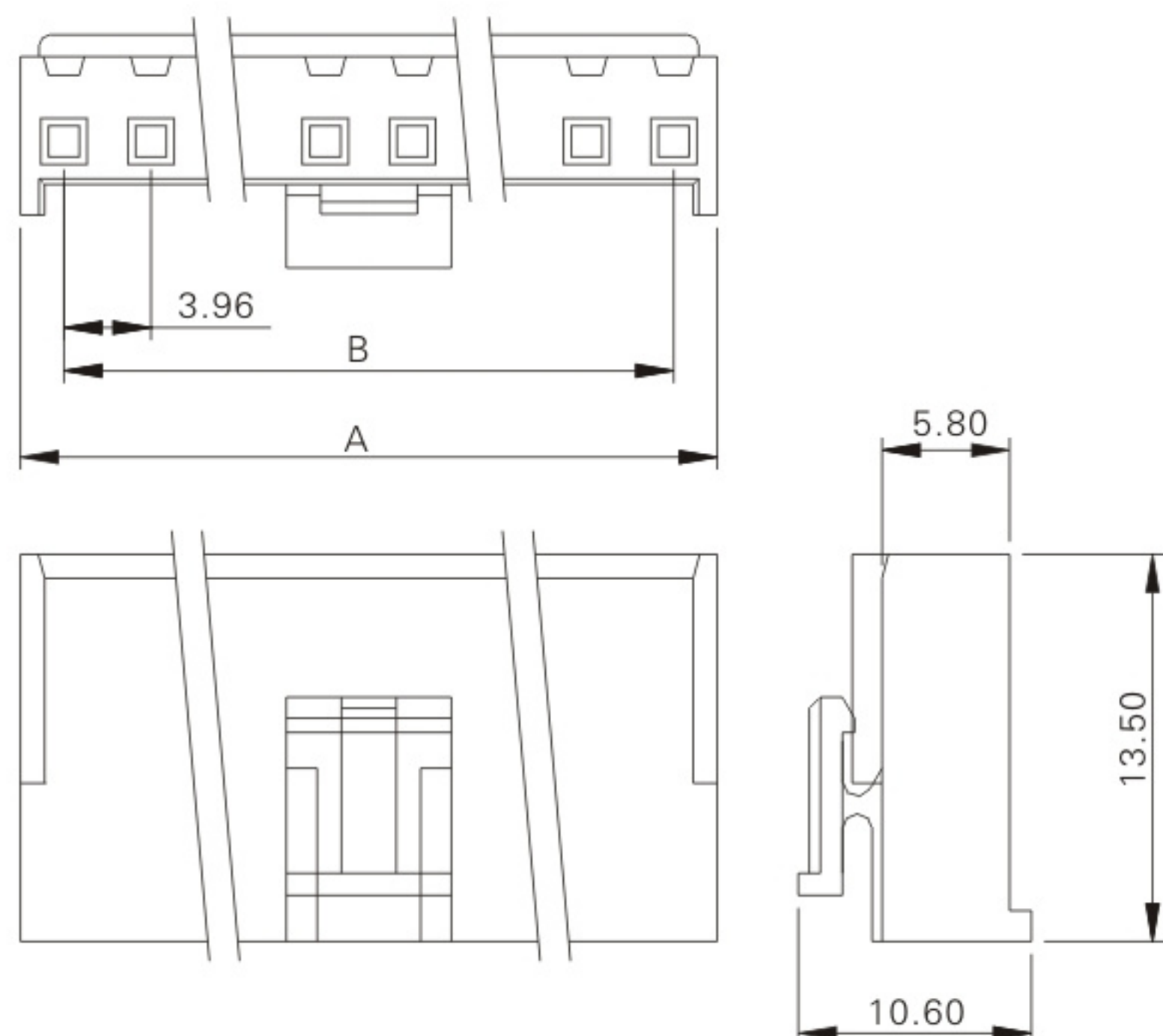

Ordering Information & Dimensions

Circuits	Part No.	DIM.(mm)	
		A	B
02	3960-02	8.22	3.96
03	3960-03	12.18	7.92
04	3960-04	16.14	11.88
05	3960-05	20.10	15.84
06	3960-06	24.06	19.80
07	3960-07	28.02	23.76
08	3960-08	31.98	27.72
09	3960-09	35.94	31.68
10	3960-10	39.90	35.64
11	3960-11	43.86	39.60
12	3960-12	47.87	43.56

3961 3961-03N2 (3.96mm pitch 180° wafer)

Reference Informations:

- *Mat'l: Body: Nylon 66 UL94V-0
Pins: Brass Tin Plated
- *Mates With: 3911 3914 series Terminal
- *Accepts With: 3960 series Housing

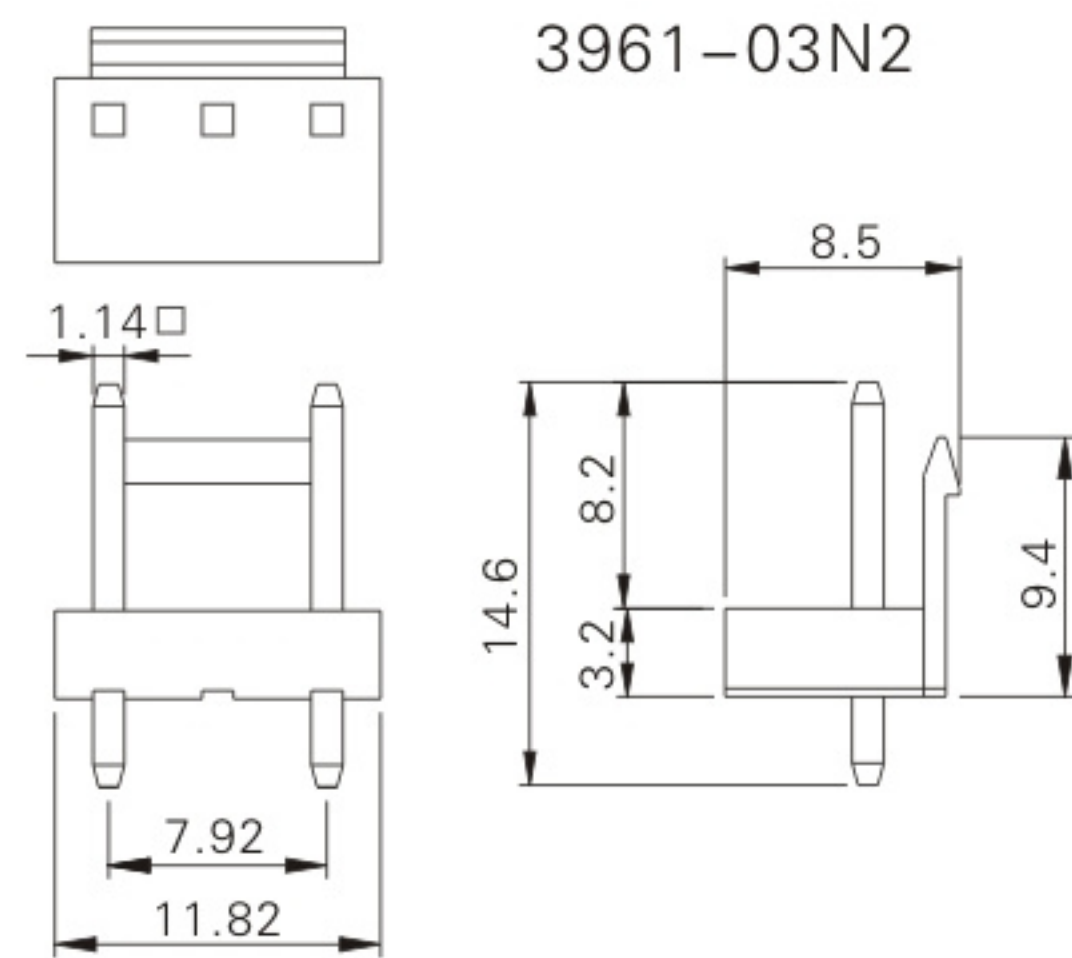
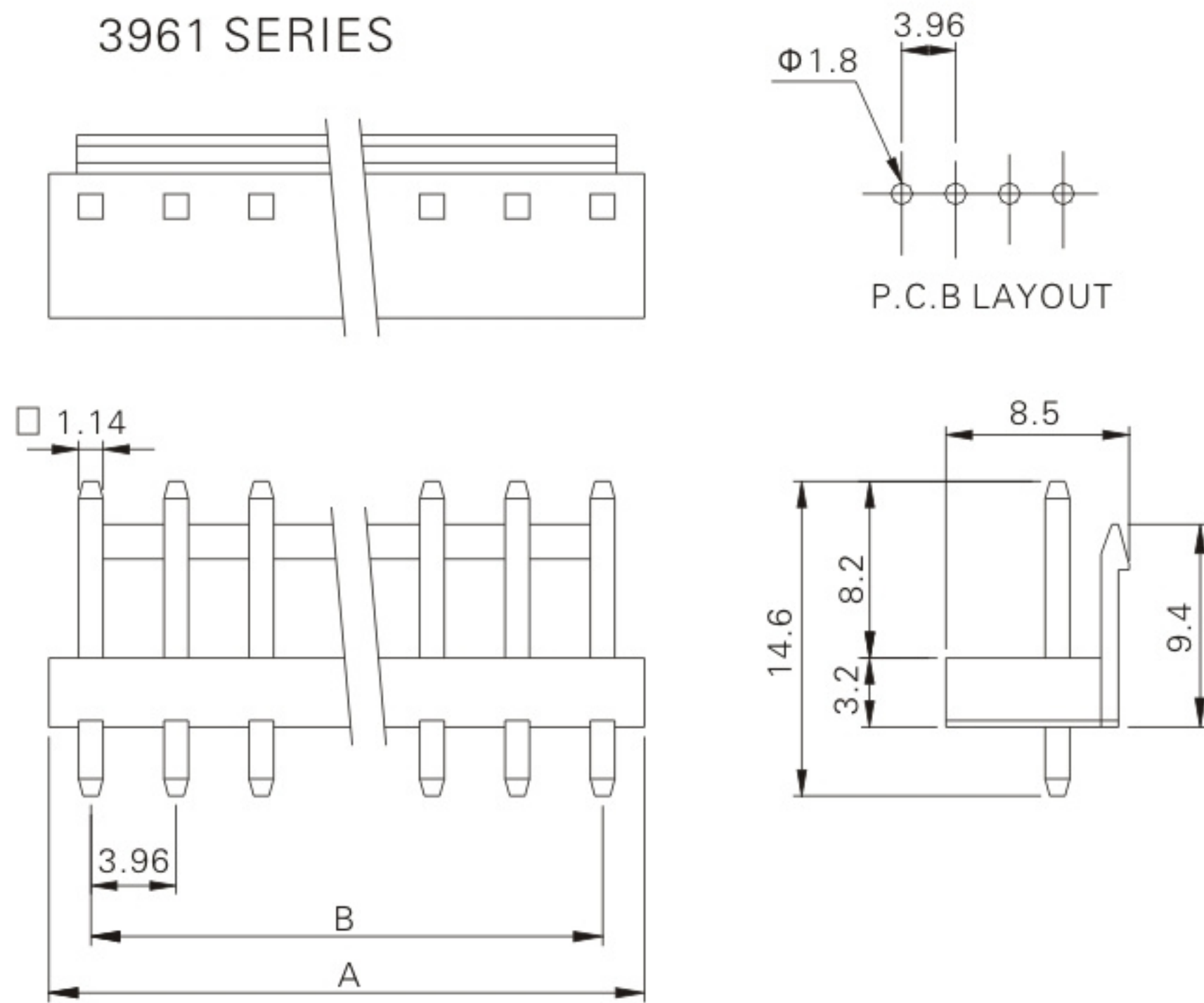

Ordering Information & Dimensions

Circuits	Part No.	DIM.(mm)	
		A	B
02	3961-02	7.92	3.96
03	3961-03	11.88	7.92
04	3961-04	15.84	11.88
05	3961-05	19.80	15.84
06	3961-06	23.76	19.80
07	3961-07	27.72	23.76
08	3961-08	31.68	27.72
09	3961-09	35.64	31.68
10	3961-10	39.60	35.64
11	3961-11	43.56	39.60
12	3961-12	47.52	43.56

3962-NP (3.96mm pitch 90° wafer)

Reference Informations:

- *Mat'l: Body: Nylon 66 UL94V-0
Pins: Brass Tin Plated
- *Mates With: 3911 3914 series Terminal
- *Accepts With: 3960 series Housing

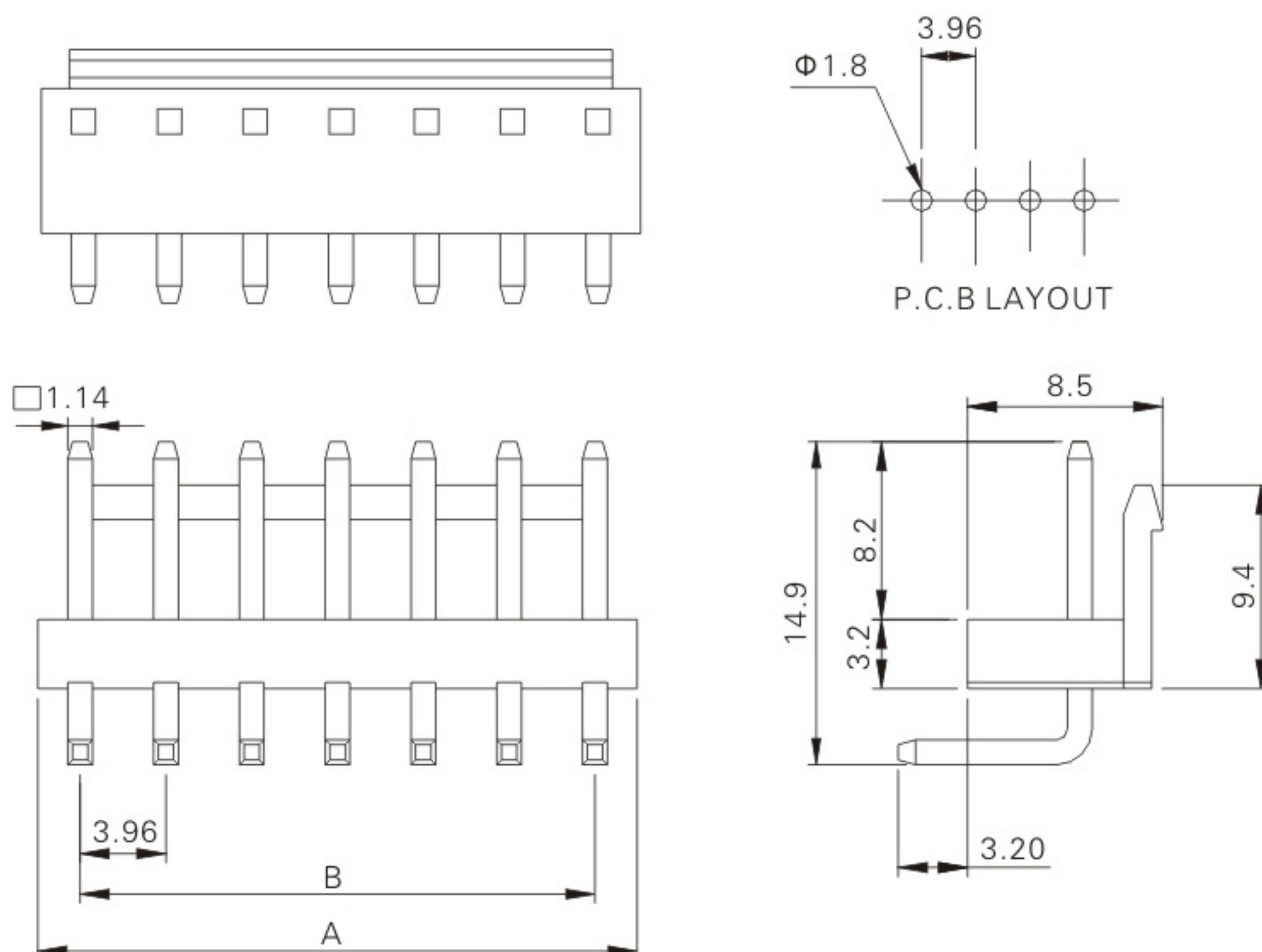

Ordering Information & Dimensions

Circuits	Part No.	DIM.(mm)	
		A	B
02	3962-02P	7.92	3.96
03	3962-03P	11.88	7.92
04	3962-04P	15.84	11.88
05	3962-05P	19.80	15.84
06	3962-06P	23.76	19.80
07	3962-07P	27.72	23.76
08	3962-08P	31.68	27.72
09	3962-09P	35.64	31.68
10	3962-10P	39.60	35.64
11	3962-11P	43.56	39.60
12	3962-12P	47.52	43.56